





**SERVICE MANUAL**  
**Weighmaster 5/5 S**  
ID: 00807248

**Symbols used in this manual**

	<b>WARNING</b> Used in case of danger of a serious accident or when documentation needs to be consulted.
	<b>NOTE</b> Used to direct attention to a special item.

© Copyright 2003

Jouan Nordic A/S  
Gydevang 17-19  
DK-3450 Allerød  
Denmark

Telephone +45 48 16 62 00  
Fax +45 48 16 62 97  
e-mail [info@jouannordic.com](mailto:info@jouannordic.com)

Home page: <http://www.jouannordic.com>

## Table of contents

<b>1.</b>	<b>Introduction .....</b>	<b>4</b>
<b>2.</b>	<b>Test and adjustment procedures .....</b>	<b>4</b>
2.1.	Alternative leak tests using a linear particle counter .....	4
2.2.	Alternative test for measuring inflow air velocity .....	5
2.3.	Flow sensor alarm adjustment.....	6
2.4.	Inflow alarm adjustment.....	8
<b>3.</b>	<b>Dismantling and replacement instructions.....</b>	<b>8</b>
3.1.	Fans .....	8
3.2.	Access to the electromechanical panel.....	9
3.3.	Windows.....	10
3.4.	Wire for the sliding front window .....	11
3.5.	Motors for sliding front window .....	12
3.6.	Motor for tightening against gasket.....	13
3.7.	Position of Front Window.....	13
3.8.	Controller board PCB .....	13
3.9.	E-prom .....	14
3.10.	Display PCB .....	15
3.11.	Key switch .....	15
<b>4.</b>	<b>Electric diagrams.....</b>	<b>16</b>
4.1.	Main diagrams .....	16
4.2.	External alarm .....	19
4.3.	Coupled control internal fan.....	20
4.4.	Coupled control external fan.....	21
4.5.	Coupled control damper motor .....	22
4.6.	Coupled control external fan normal and reduced speed.....	23
4.7.	Solenoid valve .....	24
4.8.	Battery backup .....	25
4.9.	Setting the DIL-switches.....	26
<b>5.</b>	<b>Setting of autotransformer for fan .....</b>	<b>26</b>
<b>6.</b>	<b>Spare parts.....</b>	<b>29</b>

## 1. Introduction

This Service Manual for Weighmaster 5/5S is meant to assist in performing service. It is to be used in conjunction with the Instruction Manual.

## 2. Test and adjustment procedures

The test procedures are only given as guide lines. Special rules in different countries may require specific procedures.

To ensure safe operation the setting of the alarm of Weighmaster 5/5S should be checked/adjusted whenever maintenance/repair has been performed.

	<p>All measuring instruments used for testing and adjusting must be calibrated and traceably to a national standard.</p> <p>When a technician choose an alternate measuring method than the standard measuring method, described in the Instruction Manual, the responsibility of the correlation between the measuring methods lays upon the technician and his company.</p>
---	---

### 2.1. Alternative leak tests using a linear particle counter

The particle counter method is an alternative to the photometer method, but the two methods are not necessarily equivalent (IES-RP-006.2-1996 §6.2).

Apparatus for this test consist of:

- A discrete-particle counter having a known sample flow rate and the capability to detect the particle size designated in the challenge aerosol.
- A sampling probe of square or rectangular configuration, whose inlet air velocity, approximates.
- The filter exit air velocity when, used with the discrete particle counter.
- A suitable aerosol source appropriates challenge aerosol concentration. The generator must be of the Laskin nozzle type-atomiser.
- A suitable dilution for using in measuring the upstream challenge concentrations when necessary.

#### Procedure:

1. Let the unit run in nominal speed for 15 minutes.
2. Induce the challenge aerosol through the "challenge" valve in the unit.
3. Measure the upstream concentration through the "measuring" valve on the unit. If available, set in a dilution equipment between the measuring valve and the particle counter. Adjust at the generator the amount of aerosol to > 2.000 particles /cu.ft, and register the concentration. The upstream concentration should be stable over time and uniform over the area immediately upstream of the filter area under test.
4. Scan the entire face of the filter for leaks, using slightly overlapping strokes of the probe, and moving the probe at a rate not exceeding the linear scan rate. The probe should be hold 25 mm from the filter plane during scanning.
5. Scan the frame and the perimeter of the filter in order to locate any leaks from sealant etc.

**Acceptance:**

Any detected particle count equal or greater than the number of particle counts, which characterise the designated leak, should be cause for sustained residence time of the probe at the leak position. The acceptance limit of a local penetration is 0.05 %  $\approx$  1/2000 of the upstream concentration.

**Example:** Upstream measuring 350.000 particles pr cu. ft.

Dilution factor 50

Acceptance downstream filter:  $\frac{350.000 * 1}{50 * 2000} = 3.5 \approx 3$  particle pr cu. ft

---

## **2.2. Alternative test for measuring inflow air velocity**

---

**Measuring of the inflow velocity with reduced aperture:**

This method can only be a guideline in estimating the inflow velocity.

The user should be able to verify the validity of the result.

The method is encumbered with a number of error possibilities why the method is only intended as a guide. Errors often occur by:

- False calculation of the reduction factor due to a difficult positioning of the anemometer and lack of control measuring of the height of the reduced aperture.
- Positioning of the anemometer in the correct geometrical measuring point. There is a tendency of tipping the probe either too far in the aperture or too far out from the interface between the cabinet and the laboratory.

**Procedure**

1. Reduce the aperture and measure the inlet air velocity in 5 even dealt spots over the reduced opening.
2. Calculate the mean value of the inflow velocities and convert it to a mean value for the whole aperture by a reduction of the measured flow in proportion to the reduction.

**Example:** The aperture is reduced from 250 mm to 50 mm corresponding to a

reduction factor on  $\left(\frac{250}{50}\right) = 5$ .

The measured mean inflow is converted with the reduction factor.

E.g.  $\frac{2.10}{5} = 0.42$  m/s

## Fixture

A method to elimination some of the systematic errors is to manufacture a fixture to the specific anemometer probe and establish a correlation to well-documented method.

The fixture can be made out of steel plate and is able to keep the anemometer in a constant position during the measuring. The pins fit into two of the holes in the tabletop.



**Figure 1**



A gauge block establishes the same height at each measuring.

With a fixture like this it is possible to establish a measuring with accuracy, that does not jeopardise the operator safety.

**Figure 2**

## 2.3. Flow sensor alarm adjustment

### Equipment required

Anemometer (Flow Master).

Stand.

Screwdriver made from plastics.

Variotransformer

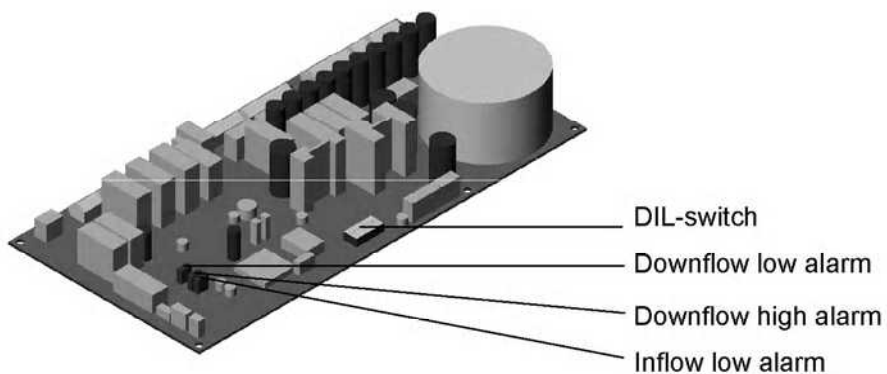

**Figure 3.**

**Procedure for low alarm adjustment**

1. Disconnect from mains.
2. Remove the cover for the electromechanical panel (see section 3.2 ) and you have access to the PCB Controller Board.
3. Set the DIL-switch 3 to ON. (See section 4.9)
4. Connect to mains and check the display to be in calibration mode.
5. Await the numbers in the display to stabilise.
6. Place the front window in work position.
7. Place the anemometer upon a stand 300 mm above the tabletop.
8. Measure the air velocity in the laminar flow as described in the Instruction Manual. (See section 6.1)
9. Find the minimum air velocity.
10. Place the anemometer where the minimum air velocity is measured.
11. Decrease the air velocity with the variotransformer until the air velocity indicator indicates mean velocity x 0.8 m/s. (Adjust to a minimum of 175 V or the electronics will not be stable.) Record the voltage over the fan.
12. Adjust potentiometers for down flow alarm so the red diode just lights up.
13. Press  $\nabla$  on the display. Check that only two segments in the bargraph will be lit.
14. Seal the screw of the potentiometer.
15. Disconnect from mains and set DIL-switch 3 to OFF.
16. Reconnect to mains and adjust the variotransformer to nominal setting.
17. Observe that alarms go out.

**Procedure for high alarm adjustment**

1. Position the anemometer where the highest down-flow is measured.
2. Increase the down-flow velocity with the variotransformer to mean velocity x 1.2 m/s.
3. Adjust the potentiometer on the Controller Board until the yellow light comes on.
4. Decrease the voltage until the high alarm goes off.
5. Readjust the voltage to achieve mean velocity x 1.2 m/s and record the voltage over the fan.
6. Seal the potentiometer.

## 2.4. Inflow alarm adjustment

### Equipment required

Balometer or Anemometer.  
Screwdriver made from plastics.  
Variotransformer

### Procedure for In flow alarm adjustment

1. Measure the Inflow velocity either with the Balometer (see section 6. 2 in the Instruction manual), or as an alternate with the Anemometer. (See section 2.2)
2. Determine the lowest permissible limit for the air velocity 0.4 m/s in the work opening by reducing the voltage on the variotransformer.
3. Adjust the potentiometer for Inflow alarm so that the red diode just lights up.
4. Adjust the variotransformer to nominal setting and check the alarm to go out.
5. Seal the potentiometer.

## 3. Dismantling and replacement instructions



Prior to performing any work in the chamber ensure that the cabinet is disinfected and/or neutralised.

### 3.1. Fans

The cabinets are equipped with 1 or 2 main fans and 1 exhaust fan. They are all directly driven AC models designed for long life performance and are all lifetime lubricated. They have built-on capacitors and may be adjusted by changing voltage on the transformers in the electric compartment.

### Equipment required

Fan  
Phillips screwdriver  
13 mm fork wrench.

### Procedure for replacement of main fan

1. Position the front window in upper position.
2. Disconnect from mains.
3. Open the front cover.
4. Remove the main filter as described in section 10.1.2 in the Instruction manual.
5. Dismantle the wire from the terminal block on the fan.
6. Unscrew the fan from plenum.
7. Hang the fan on the fitting in the cabinet ceiling.
8. Remove the main plenum.



9. Exchange the fan.
10. Reassemble in reverse order.

### Procedure for replacement of exhaust fan

Perform steps 1 to 9 (excluding step 6) in the procedure for main fan, and continue:

10. Remove the exhaust filter according to the section concerning filter change.
11. Dismantle the wire from the terminal block on the fan.
12. Remove plenum and the fan by lifting the boom iron at the fitting on the rear.
13. Exchange the fan in plenum.
14. Reassemble in reverse order.

---

### 3.2. Access to the electromechanical panel

---

To gain access for alarm setting, window positioning, controller board, motor console and transformers the cover above the electromechanical panel must be removed.

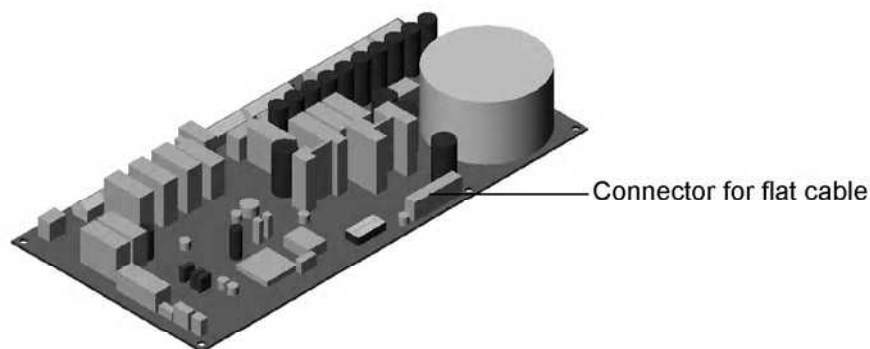

Figure 4.

#### Equipment required

Phillips screwdriver

#### Procedure

1. Unscrew the cover for the fuse compartment.
2. Remove the plug for the flat cable and terminal for earth and slide it through the slot in the cover. Be careful you don't damage the flat cable.
3. Push the rubber hose next to the opening down.
4. Remove the cover by unscrewing the 2 screws in either side and carefully lift it off.

---

### 3.3. Windows

---

#### Front window

##### Equipment required

Front window including wire and wire lock.  
Phillips screwdriver  
Support for the window e.g. tall trestles.  
Food inspection approved lubricant.

##### Procedure for replacement of front window

1. Lower the front window. Stop immediately prior to reaching the lowest position to avoid the window from sticking to the frame.
2. Disconnect the cabinet from mains.
3. Dismantle the front cover.
4. Remove the cover from the electromechanical panel
5. Push the window gently upwards and out of the guides. Leave it resting against the supports so there is no tension on the wires.
6. Remove the wire from the wire wheels on the motor console by unscrewing the screw on the end of the axle. Wheel and wire may now be removed.
7. Window and wire may be removed and replaced by a new.
8. Reassemble in reverse order. Assembling wire and wire wheel is described in section 3.4. Do remember lubrication.

#### Side window

##### Equipment required

Right or left side window.  
Phillips screwdriver.  
Sharp knife for cleaning off silicone joints.  
Silicone detergent.

##### Procedure for replacement of side window

1. Drive the window to the top position.
2. Open the front cover.
3. Disconnect from mains.
4. Unscrew the side cover from the side profile.
5. Unscrew the 6 screws holding the side profile.
6. Cut away the silicone joint.
7. Carefully pull the side profile forward to enable removal of the side window.

8. Clean away silicone remains.
9. Install the new window and apply silicone.
10. Reinstall in reverse order. Remember to tighten the top threaded bushing holding the lampshade. Access is gained by removing the cover of the electromechanical panel.

---

### 3.4. Wire for the sliding front window

---

#### Description

The hoisting mechanism for raising and lowering the front window is designed with two wires, in which the window hangs. These wires must always be tight during operation. To ensure this, the mechanism is equipped with a micro switch, which is normally switched on. In case of irregularity with the wires, e.g. slack or broken wires, the micro switch will ensure that the window can't be raised.

Each wire is designed to hold approximately 10 times the weight of the window. If both wires break simultaneously - which is highly unlikely - the safety latch will catch the falling window.

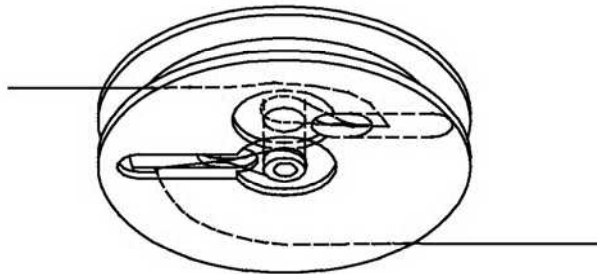

Figure 5.

#### Equipment required

Lubricant  
Set of wires  
7 mm fork wrench.  
Phillips screwdriver

#### Procedure for replacement of wire

1. Perform steps 1 to 7 of the procedure for exchanging the front window.
2. Remove the 2 small clamp fitting on the window frame.
3. Remove the safety latch and then the wire may be removed.
4. Reassemble in reverse order with the new wire in place.  
Do remember lubrication.
5. The inner wire must be twisted counter clockwise and be moved to the left.
6. The outer wire must also be twisted counter clockwise but moved to the right.
7. Note that the wire wheel is not symmetrical. The flat side must be inwards.
8. Adjust the window to horizontal by pushing motor console sideways. Unscrewing the 2 threaded rods from the brass wheel and loosening the 6 nuts on the motor console performs this. When the window hangs straight adjust the threaded rods so they both push the fork ends in either side maximum (without bending).

### 3.5. Motors for sliding front window

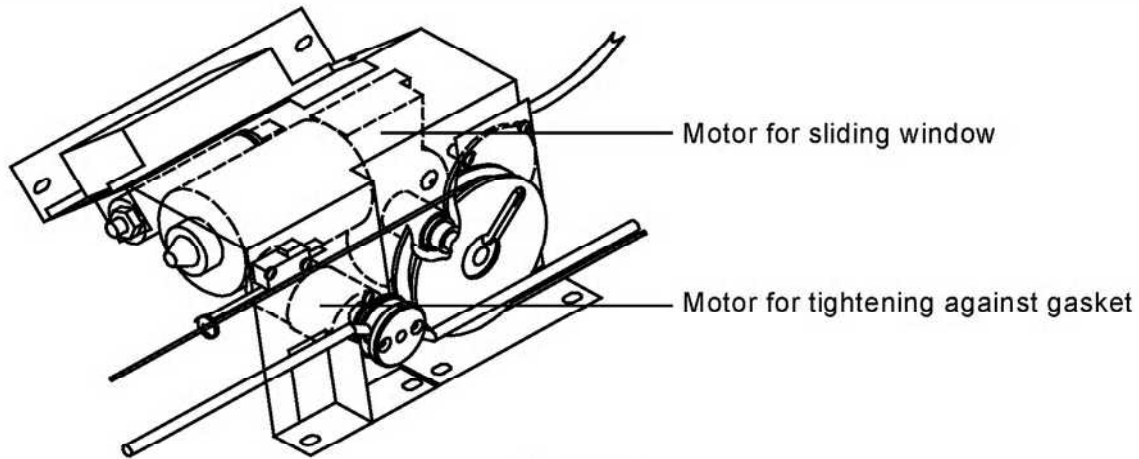

Figure 6a.

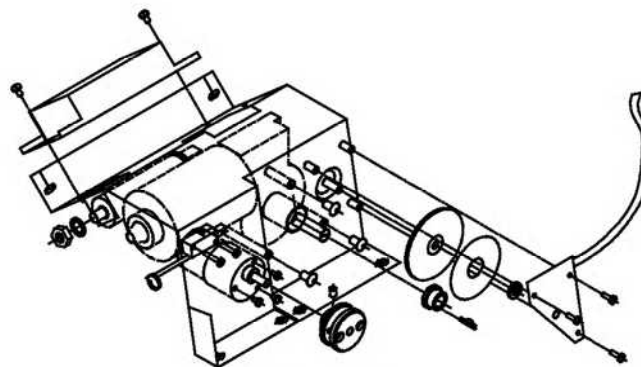

Figure 6b.

#### Equipment required

Large gear motor.  
Phillips screwdriver.  
7mm wrench.

#### Procedure for replacing the motor for the sliding front window

1. Lower the front window to lowest position.
2. Disconnect from mains.
3. Dismantle the cover of the electromechanical panel as described in section 3.2.
4. Dismantle the wires for motor and the Window Position PCB on the controller print.
5. Remove the wire wheel and the wire.
6. Remove the gear wheel.
7. Dismantle the threaded rods on the brass wheel.
8. Unscrew the motor console.
9. Replace the motor and reassemble in reverse order.
10. See section 3.7 concerning high adjustment of the front window.

### 3.6. Motor for tightening against gasket

#### Equipment required

Small gear motor.  
Allan key size 3 mm.  
Small Phillips screwdriver.  
Food inspection approved lubricant.

#### Procedure for exchange of motor for tightening against gasket

1. Follow steps 1 to 3 in section 3.5.
2. Cut off the thread bars.
3. Remove the brass wheel using the Allen key.
4. Remove the electric wires.
5. Unscrew the motor.
6. Reassemble in reverse order. Do remember lubrication.

### 3.7. Position of Front Window

The window position is detected by an optical system on the electromechanical panel.

Activate  and  and  simultaneously and the position is displayed.

In the table below window position and corresponding detection values are shown.

If e.g. Pos 3 and the window is in work position - agreement exists.

Window position	Display
Bottom position	Pos. 01
Lower range (lower 250 mm)	Pos. 02
Work position (At 250 mm $\pm$ 5 mm)	Pos. 03
Upper range (upper 250 mm)	Pos. 04
Top position	Pos. 05
Between upper range and top position	Pos. 06
Between lower range and bottom position	Pos. 07
ERROR	Pos. 00

Disagreement between the values might be caused by incorrect adjustment of the encoder disk for window position detection. The disk may be adjusted by twisting the print on the motor console around the centre or by changing the mesh between the two gear wheels. See figure 6b in section 3.5.

### 3.8. Controller board PCB

#### Equipment required

Controller board PCB.  
5 mm wrench.  
Anti-static wristband.

### Procedure for exchange of the PCB

1. Drive the window to the lowest position.
2. Disconnect from mains.
3. Using anti static wristband connected to the frame when the prints are touched, dismantle all wires and sockets on the print.
4. Unscrew the print.
5. Reassemble in reverse order.
6. Reprogram functions according to the Instruction Manual.
7. Adjust the flow alarms. See section 2.3.
8. Set the DIL-switches as on the removed print.

---

### 3.9. E-prom

---

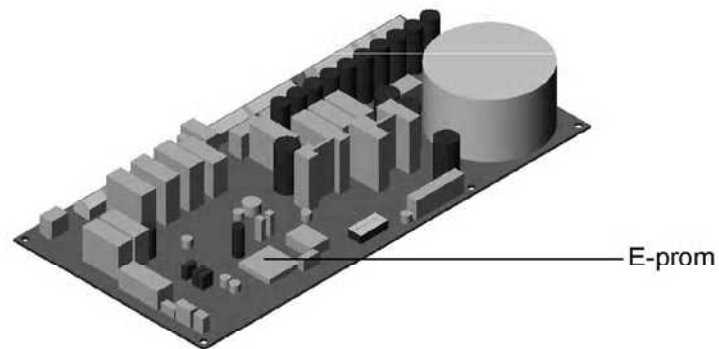

Figure 7a.



Figure 7b.

### Equipment required

- PLCC extraction tool.
- E-prom.
- Anti-static wristband.

**Procedure for exchange of E-prom**

1. Disconnect from mains.
2. Using anti static wristband connected to the frame when the prints are touched, dismantle the cover of the electromechanical panel as described in section 3.2.
3. Exchange the E-Prom making sure the orientation is correct.
4. Reprogram functions according to the Instruction Manual.
5. Adjust the flow alarms. See section 2.3 and 2.4.

---

**3.10. Display PCB**

---

**Equipment required**

Display PCB.  
Phillips screwdriver.  
5mm wrench.

**Procedure for replacement of display PCB**

1. Bring the front window in the lowest position.
2. Disconnect from mains.
3. Dismantle the flat cable.
4. Lift the front cover.
5. Remove the cover over the display PCB by pushing it against the top.
6. Disconnect the wire to the key switch.
7. Unscrew the print and reassemble in the reverse order.
8. Check all functions.

---

**3.11. Key switch**

---

**Equipment required**

Key switch including keys.  
20 mm wrench or fork wrench.  
Graphite dust (Optionally).

**Procedure for replacement of key switch**

1. Adhere to the procedure for replacement of display PCB.
2. Unscrew the key switch and replace it. In case the key is hard to turn, use graphite dust.

4. Electric diagrams

4.1. Main diagrams

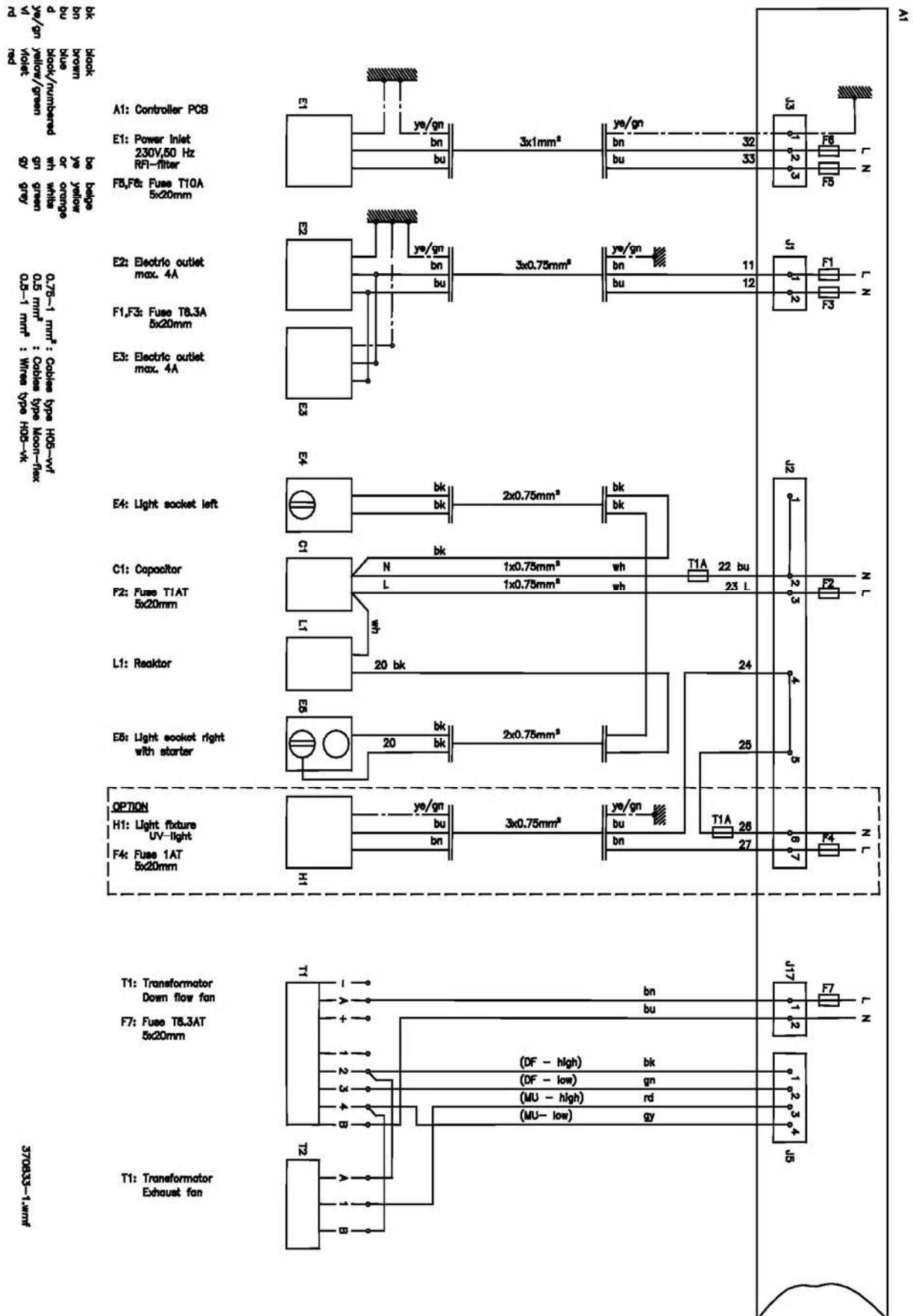



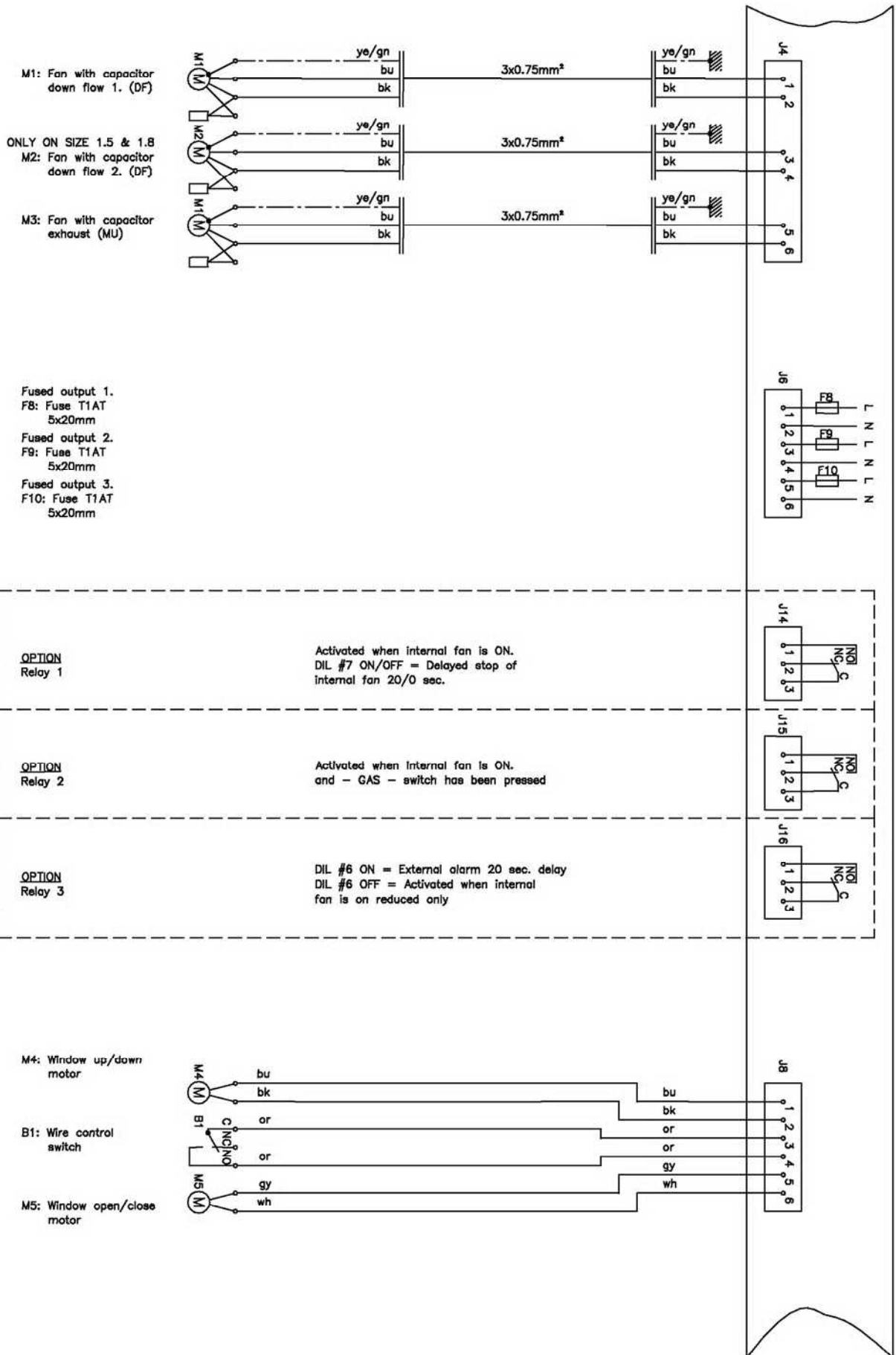

370833-2.wmf

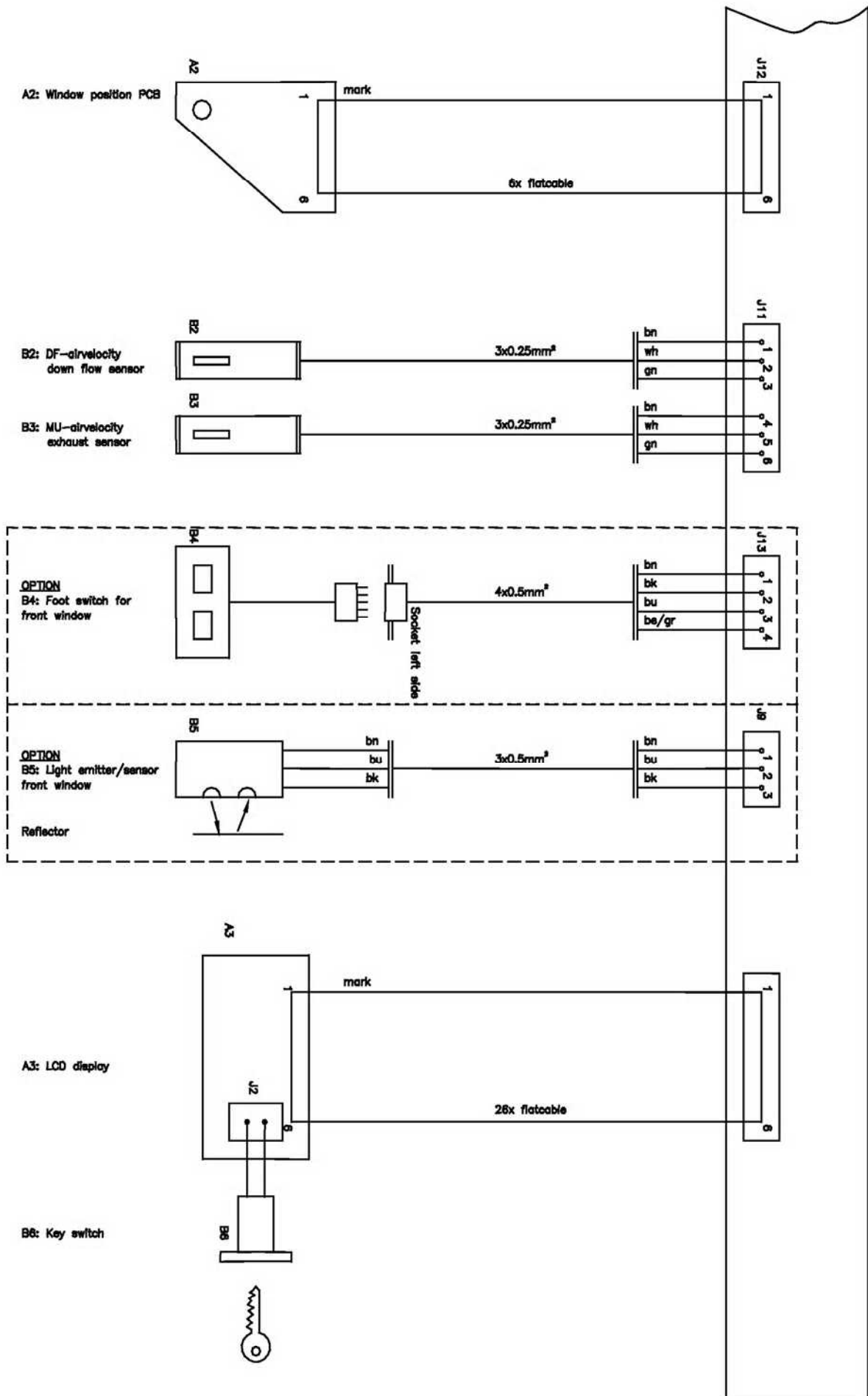

370833-3.wmf

4.2. External alarm

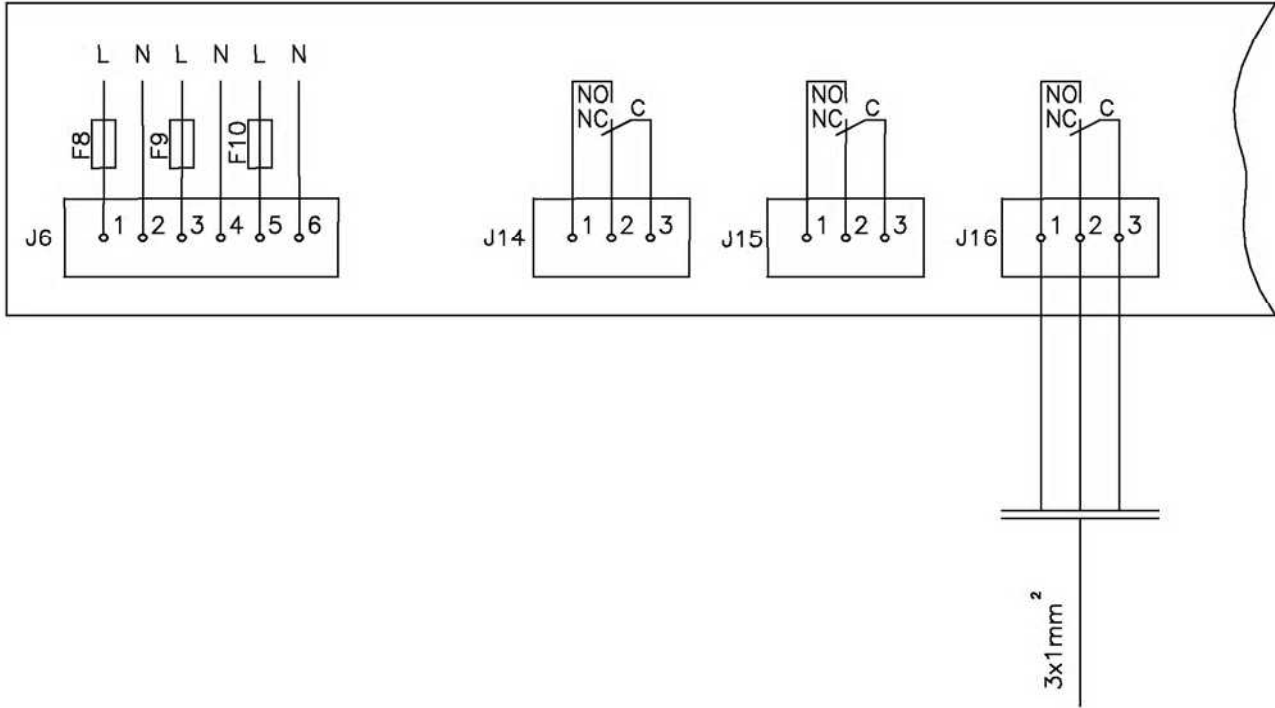

DIL #6: ON

Relay 3: External alarm 20 sec. delayed  
Max. load 230V 1 Amp.

4.3. Coupled control internal fan

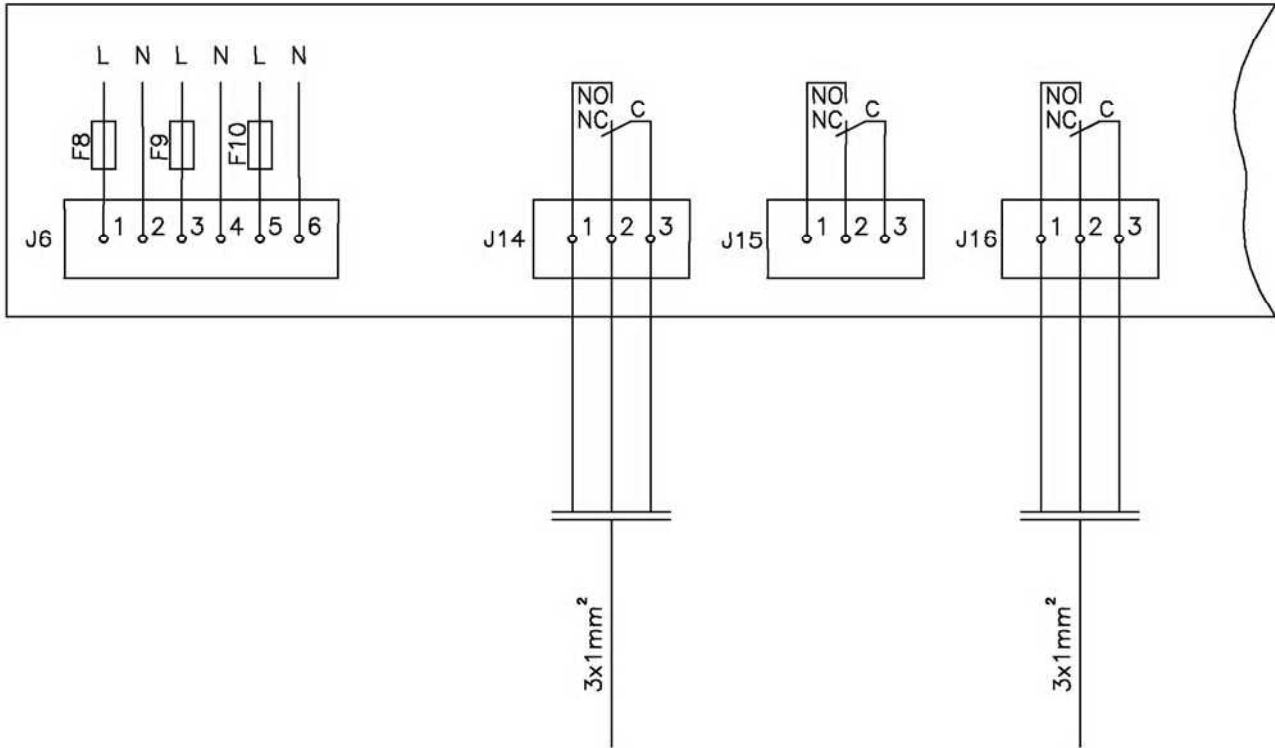

Relay 1: Internal fan ON at normal or reduced velocity. Max load 230V 1 Amp.  
DIL #7: ON gives 20 sec. delayed stop of internal fan

Relay 3: Internal fan ON at reduced velocity.  
Max load 230V 1 Amp.

4.4. Coupled control external fan

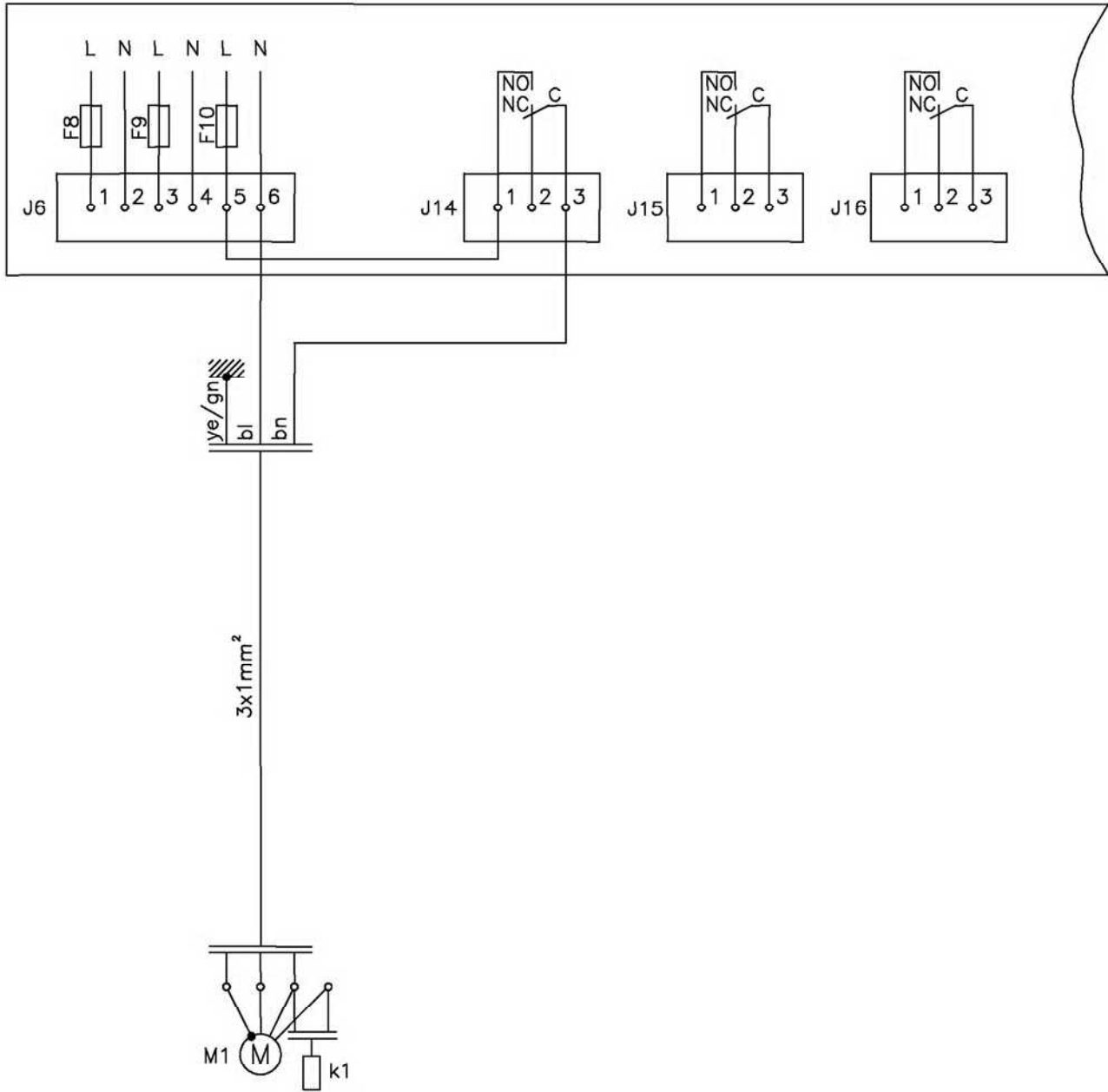

M1: External fan  
 230V 50 Hz  
 max. 200 VA

F10: Fuse T1A  
 5x20mm

bk	black	be	beige
bn	brown	ye	yellow
bl	blue	or	orange
d	black/numbered	wh	white
ye/gn	yellow/green	gn	green
vi	violet	gr	grey
rd	red		

4.5. Coupled control damper motor

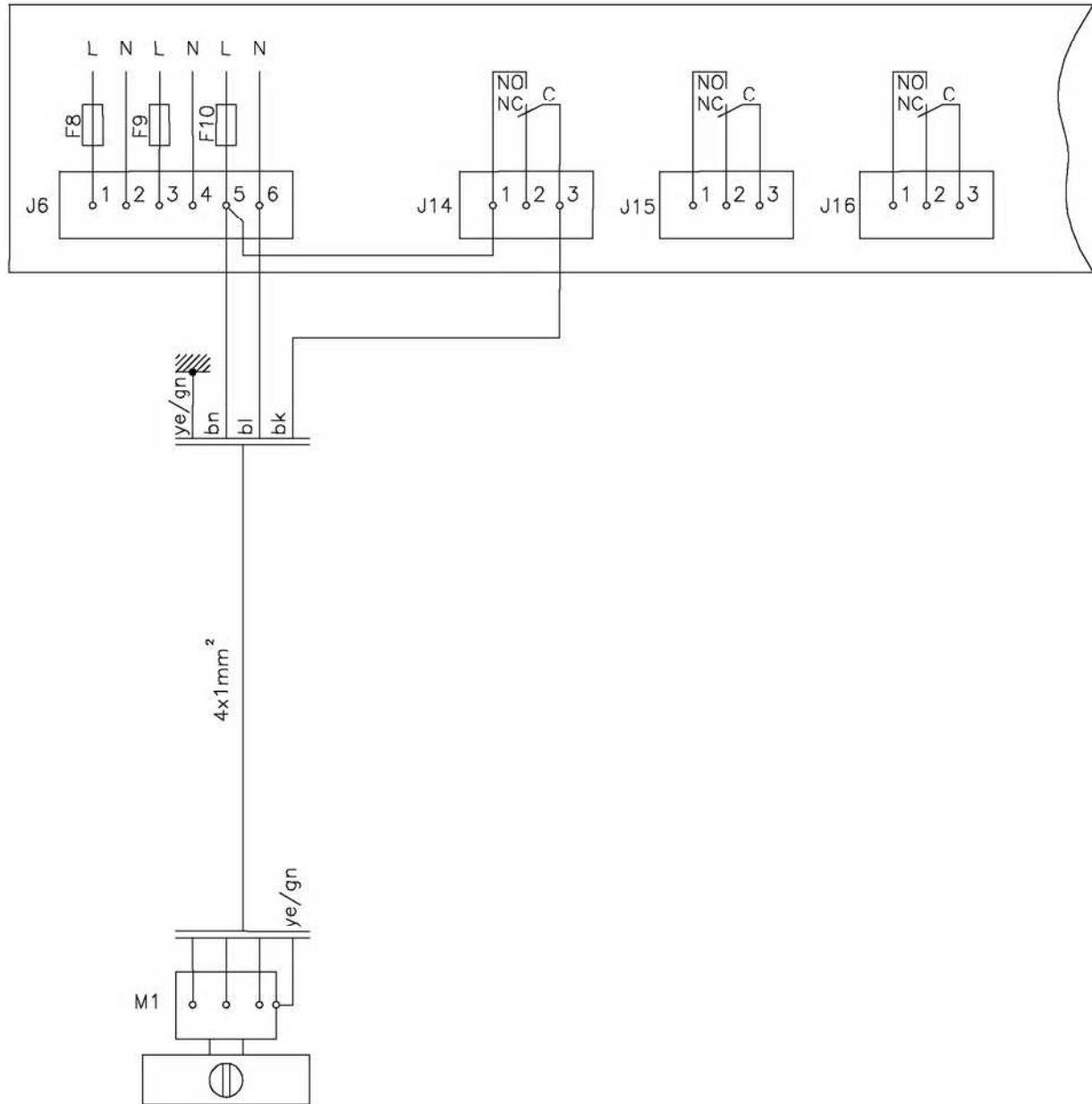

M1: Damper motor  
 230V 50 Hz  
 F10: Fuse T1A  
 5x20mm

When using both fan and damper for the same cabinet, remember to built in relays between option relay and unit.

bk	black	be	beige
bn	brown	ye	yellow
bl	blue	or	orange
d	black/numbered	wh	white
ye/gn	yellow/green	gn	green
vi	violet	gr	grey
rd	red		

371400.wmf

4.6. Coupled control external fan normal and reduced speed

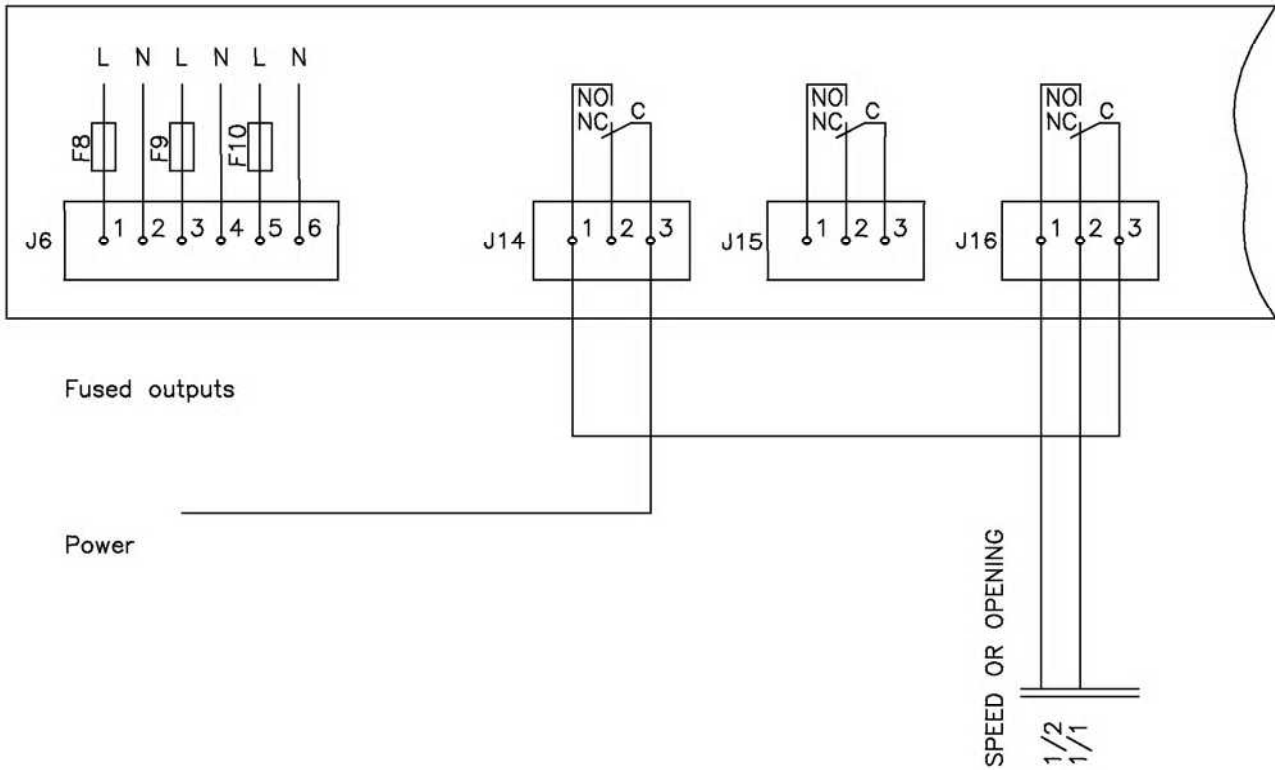

ON/OFF and 1/1 - 1/2  
FAN  
DAMPER  
OR VOLUSTAT

377730.wmf

4.7. Solenoid valve

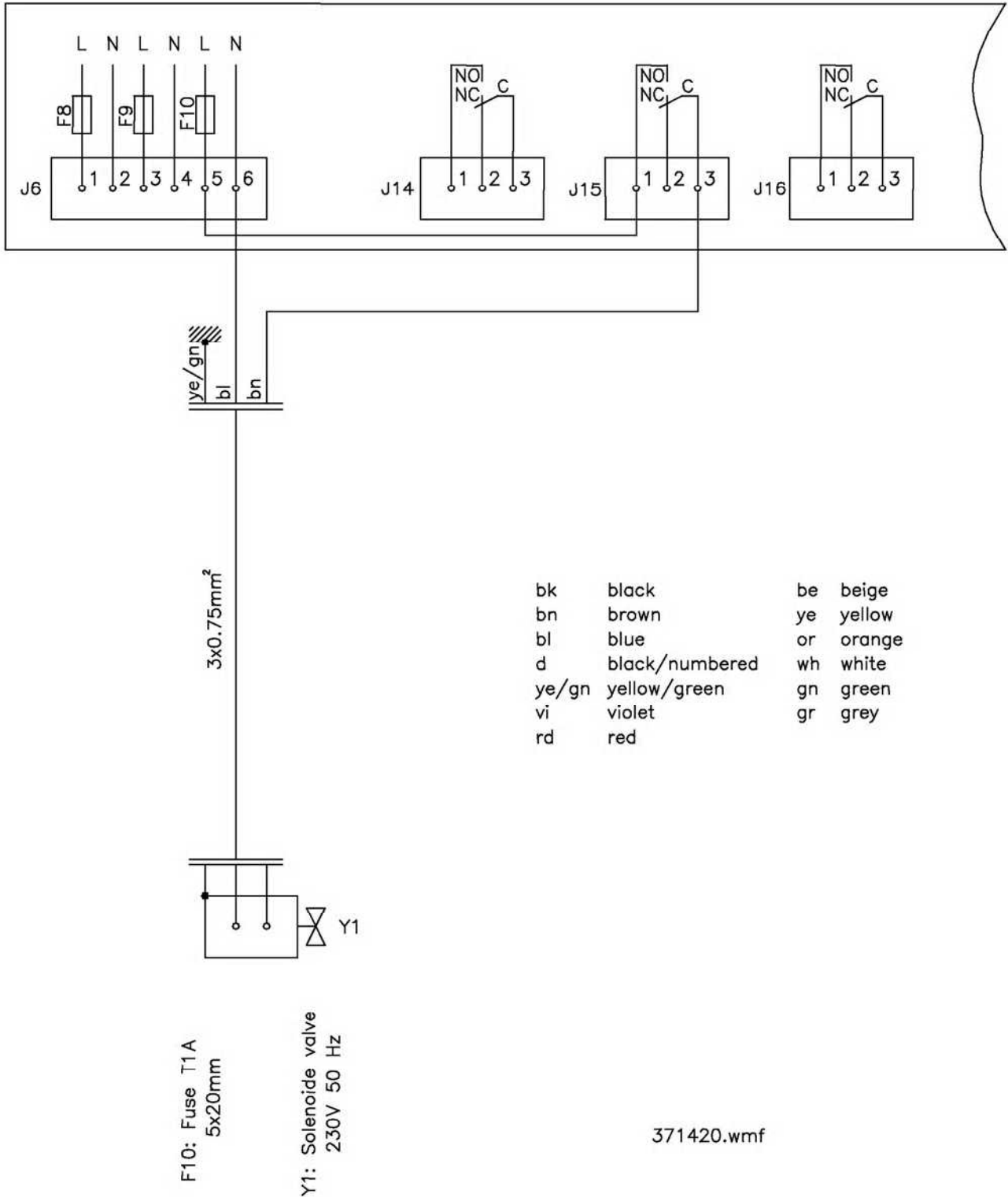



4.8. Battery backup

571351.mmF

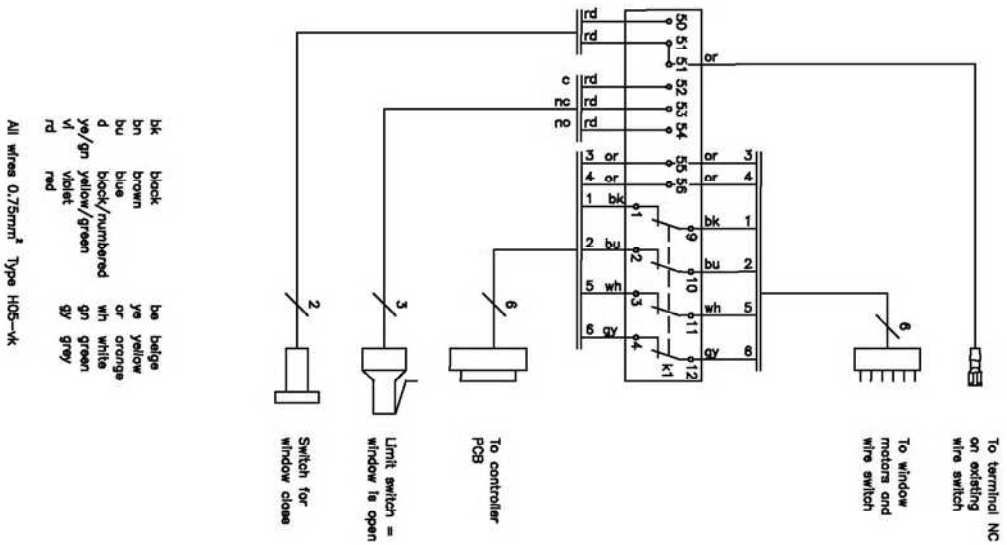
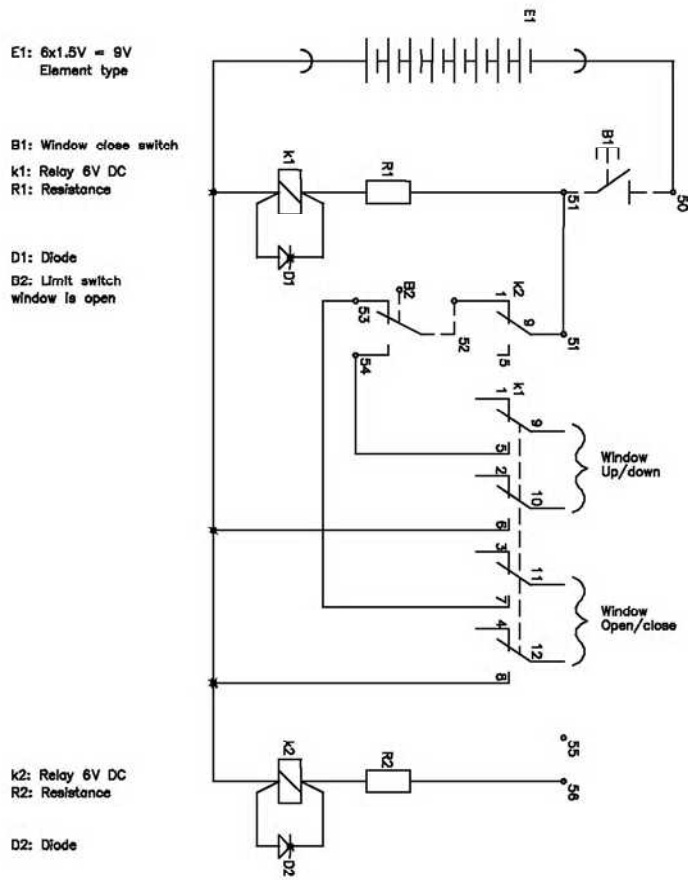

#### 4.9. Setting the DIL-switches

During installation of options available for the Weighmaster 5 og 5 S cabinet the DIL-switches positioned on the controller board PCB must be adjusted.

Before adjusting the DIL-switches the cabinet must be turned off.

The table shows the position of the DIL-switches depending on the option:

DIL-switches decoding

DIL-switch no.	OFF	ON
1	50 Hz	60 Hz
2	Ventilator function NORMAL	Only NORMAL and reduced ventilator enabled
3	NORMAL operations mode	Calibration mode
4	UV function not enabled	UV function enabled
5	NORMAL operation mode	Programme switch mode
6	External signal when velocity reduced	External signal on alarm, a delay of 20 seconds is in effect
7	No tails on the internal ventilator	20 seconds tails on the internal ventilator when the external ventilator is engaged
8	NORMAL operations mode	Burn in test program

Find the controller board PCB on which the DIL-switches are located. See section 3.2 regarding access to the electromechanical panel, where the PCB is located.

#### 5. Setting of autotransformer for fan

##### Primary autotransformers

ASU 96A maximum 3A  
 ASU 96 CH maximum 6A  
 230V AC

##### Secondary autotransformer

ASU 78A - 29112

##### Description

The construction of the transformer offers a number of possibilities for adjustments. The fans may be adjusted to deliver the desired volume of air. The tables below offer a wide selection of possibilities for voltage supply to the fan.

##### Equipment required

Phillips screwdriver  
 Small screwdriver for slotted screws.

##### Procedure for setting air velocity

1. Always disconnect from mains when the transformers are being adjusted.
2. Adjust the down flow using the black wire on the primary autotransformer (ASU 96...) until the average volume of air is measured according to section 2.3 at 0.4 m/s. Table 1 or 3 below.

3. Adjust the exhaust air volume using the secondary (ASU 78A) autotransformer - set the red wire in terminal point 1. The supply to the small transformer is dependent on the adjustment of the large transformer leaving limited adjustment possibilities.
4. Move the white and grey wires from A and B on the secondary autotransformer to terminal points on the primary autotransformer according to the table 2 and 4 on the following pages.
5. Find the terminals for the green (gr) and the grey (gy) wires for reduced velocity. A terminal already in use may be used for maximum one additional wire.

Standard settings:

Preconditions:	Mains voltage	230V	
Primary auto transformer	Blue wire in terminal	B	
	Green wire in terminal	4	DF,R
	Grey long wire in terminal	4	MU,R
Sec. Auto transformer	White wire in terminal	A	
	Grey short wire in terminal	B	
	Red wire in terminal	1	MU,H

**Table 1.**

Setting possibilities for **Downflow** fan normal and reduced speed, and In flow fan reduced speed.

Combination	Brown wire	Black wire	Voltage Fan <sub>DF,N</sub> V	Voltage Fan <sub>DF,R</sub> V	Voltage Fan <sub>MU,R</sub> V
A-3	A-	3	112	86	86
A-2	A-	2	140	86	86
A-1	A-	1	165	86	86
A3	A	3	118	92	92
A2	A	2	147	92	92
A1	A	1	175	92	92
A+3	A+	3	126	98	98
A+2	A+	2	157	98	98
A+1	A+	1	189	98	98

**Table 2.**

Setting possibilities for **In flow** fan normal speed in proportion to above mentioned combination possibilities.

Combination	White print card wire	Grey print card wire	Combination A-1,A-2,A-3	Combination A1,A2,A3	Combination A+1,A+2,A+3
			Voltage Fan <sub>MU,N</sub> V	Voltage Fan <sub>MU,N</sub> V	Voltage Fan <sub>MU,N</sub> V
23	2	3	118	126	135
13	1	3	125	135	145
12	1	2	145	155	164
21	2	1	152	163	174
A+2	A+	2	160	170	180
A+1	A+	1	170	180	190
1A+	1	A+	185	190	200

For certain types of cabinets it may be suitable to use below table for settings:

Alternate settings:

Preconditions:	Mains voltage	230V	
Primary auto transformer	Brown wire in terminal	B	
	Green wire in terminal	2	DF,R
	Grey long wire in terminal	2	MU,R
Sec. Auto transformer	White wire in terminal	A	
	Grey short wire in terminal	B	
	Red wire in terminal	1	MU,H

**Table 3.**

Setting possibilities for **Downflow** fan normal and reduced speed, and In flow fan reduced speed.

Combination	Blue wire	Black wire	Voltage Fan <sub>DF,N</sub> V	Voltage Fan <sub>DF,R</sub> V	Voltage Fan <sub>MU,R</sub> V
NA-3	A-	3	112	86	86
NA3	A	3	105	77	77
NA+3	A+	3	98	68	68

**Table 4.**

Setting possibilities for **in flow** fan normal speed in proportion to above mentioned combination possibilities.

Combination	White print card wire	Grey print card wire	Combination NA-3	Combination NA3	Combination NA+3
			Voltage Fan <sub>MU,N</sub> V	Voltage Fan <sub>MU,N</sub> V	Voltage Fan <sub>MU,N</sub> V
34	3	4	133	122	115
B3	B	3	151	145	141
B4	B	4	169	164	161

**Recommended settings:**

Model	Normal setting	High setting	Low setting
Weighmaster 5 / 5 S 1.2			
Weighmaster 5 / 5 S 1.8			

**Compensation** for Mains voltages different from 230V:

$$V = V_{\text{Actual}} / 230 \times V_{\text{Table}}$$

E.g. Mains voltage = 240 V and table value = 160V:

$$V = 240 / 230 \times 160 = 167$$

## 6. Spare parts

See Instruction Manual regarding filters, light tubes (normal and UV), starter and fuses.

Model Catalogue number Item	S1.2 57250200	S1.8 57270200
Main fan*		822458
Exhaust fan		822459
Primary transformer	847225	847226
Secondary transformer		847227
Controller board		849141
E-prom		849143
Display board		849137
Window position PCB		849145
Flow sensor		849118
Key switch		841048
Safety switch		903325
IEC connector filter		88856008
Motor console (complete)		57250225
Large gear motor		88847442
Small gear motor		88847439
Choke coil	844059	844060
Capacitor	847002	847003
Front cover	57250204	57270204
Gas spring	822205	822226
Wire	973120+973121	973120+973123
Front window	Nyt nummer	Nyt nummer
Gasket	2.6 x 832441	3.2 x 832441
Flock filter	973067	973069
Pulley fitting		2 x 903309
Safety latch (set)		57250211
Fork		88822942
Distance piece for display PCB		973119
Set of belts		2 x 973128+2 x 973129
Side windows:		
Left		85440263
Right		85440264
Tabletop		973005
Valve Ballofix ½"		88823746
Arm rest		973169
Silicone (tube)		88831212
Weight stone		831901
Plastic spacer kit		1 x 973153 / 2 x 973154
Weight tabletop		973150

<b>Installation kits</b>	
<b>Item</b>	<b>Catalogue number</b>
Gas re-settable solenoid valve	80100001
Gas	80100022
Carbon-dioxide	80100023
Vacuum	80100024
Nitrogen	80100025
Oxygen	80100026